

Topcon Liftlog 1000

Forklift truck weighing system



With the ever increasing focus on productivity and safe-loading, the LIFTLOG 1000 is a cost-effective weighing instrument that reduces loading cycle times and maximises tons per hour performance.

Learn more at topconpositioning.com

 **TOPCON**

0.5% accuracy designed specifically for forklift trucks operating in the fastest loading environments

The LIFTLOG 1000 is an operator friendly product that has been specifically designed for use on forklift trucks working in a despatch yard or warehouse environment. Weighing on the forklift removes the need to travel to a static floor scale often remotely located from the stock location or loading bay. Loading correctly first time eradicates return trips to the stockpile reducing vehicle movement, fuel usage, machine and tyre wear.

Using a sensor to measure hydraulic pressure controlled in a drop valve, the LIFTLOG 1000 informs the operator of load as a 'calculated' weight in Tonnes, kgs, lbs and US Tons. This load can then be confirmed automatically or via the 'Enter' button and added to the Accumulated total and will also be added to the Grand total. In addition, when approaching and at the point of

» Compatible with RDS iSOSYNC PC software.

Additional Options:

- » A variety of external audible alarms for use in noisy environments.
- » Remote weigh button.
- » Remote enter button.

overload, an internal (and optional external) alarm will sound to further inform the operator of load status. Approximate load is indicated via an on-screen Load bar.

Schematic

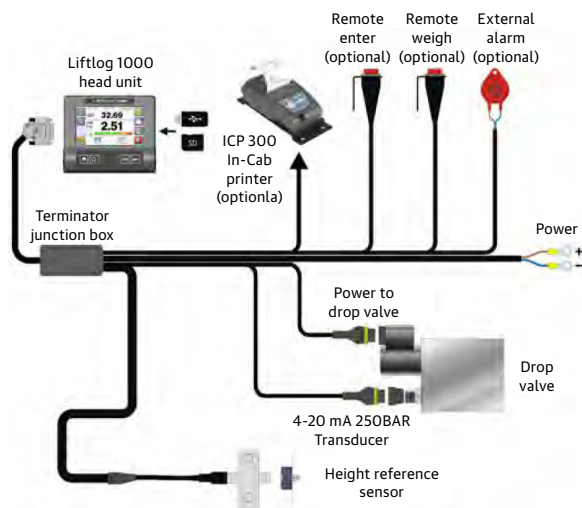

TECHNICAL DETAILS

Operating voltage	12 Vdc
Sensor range	0 - 250 bar
Temperature range	-5 to +160 °F operating
System accuracy	+/- 0.5% of truck capacity
Warranty	1 year
Environmental unit protection	Instrument protection IP54 Full RFI/EMI Sensor & valve IP67

Specifications subject to change without notice.

© 2025 Topcon Corporation. All rights reserved. 7010-2448 A 02/25

Learn more at topconpositioning.com

